

IPS Camel By Vintage 1

24 March 2004, Issue 2.01

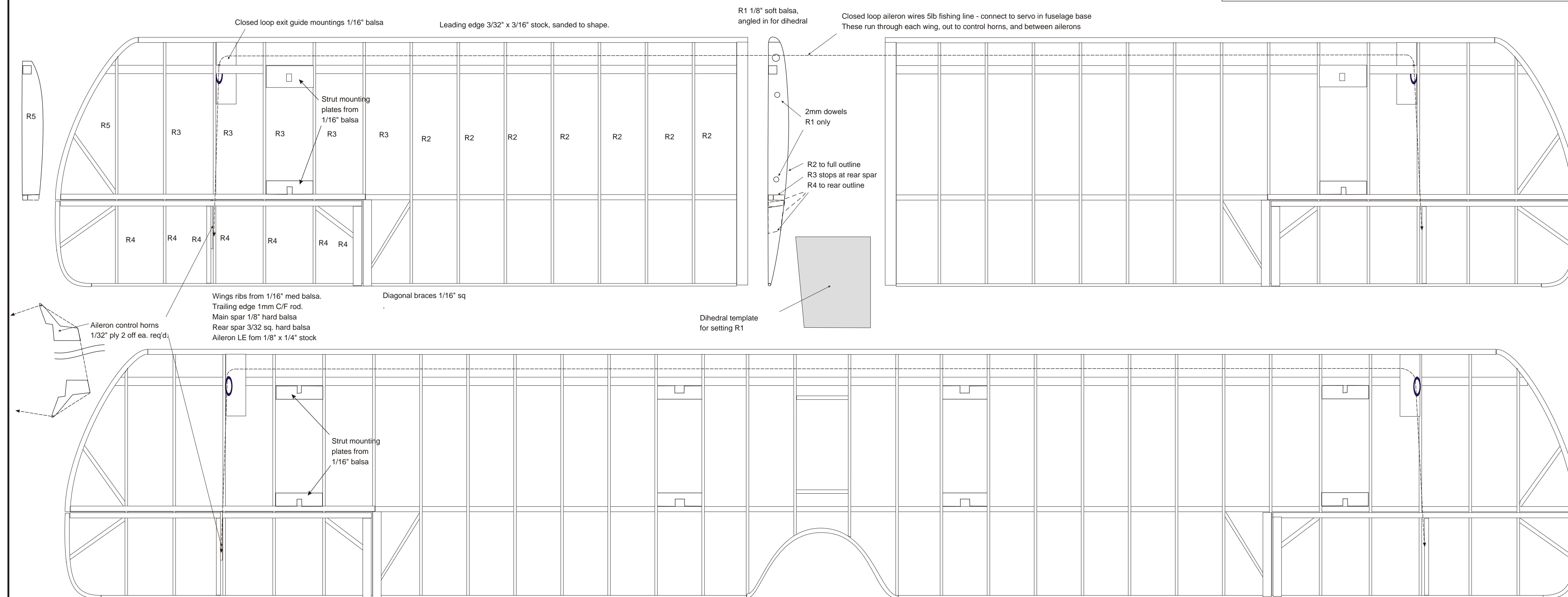

Cabane Strut Alignment Jig. locates on H1 and tailplane seating. Construction 1/8" ply or liteply

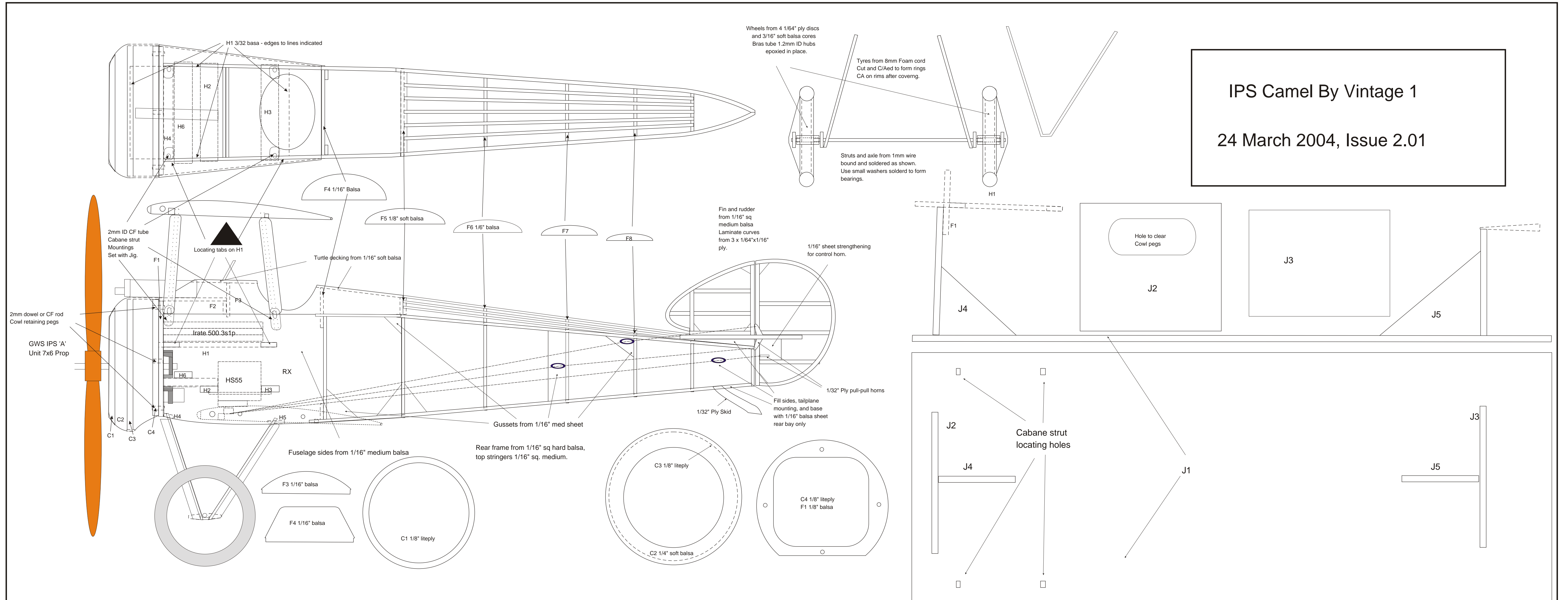
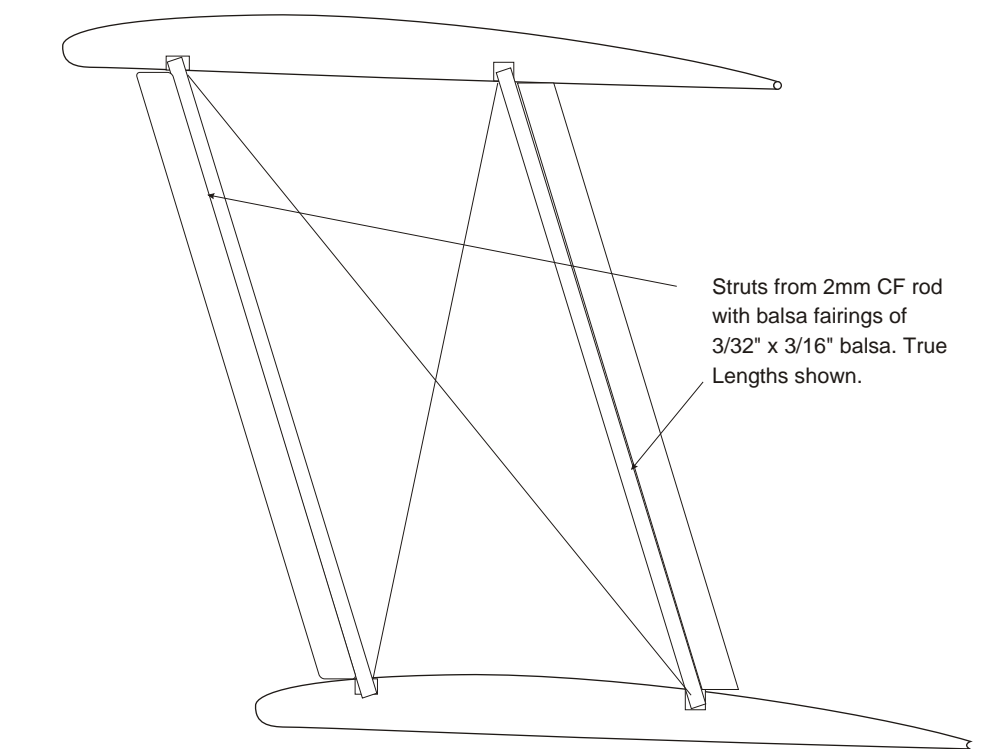

Interplane struts and optional rigging

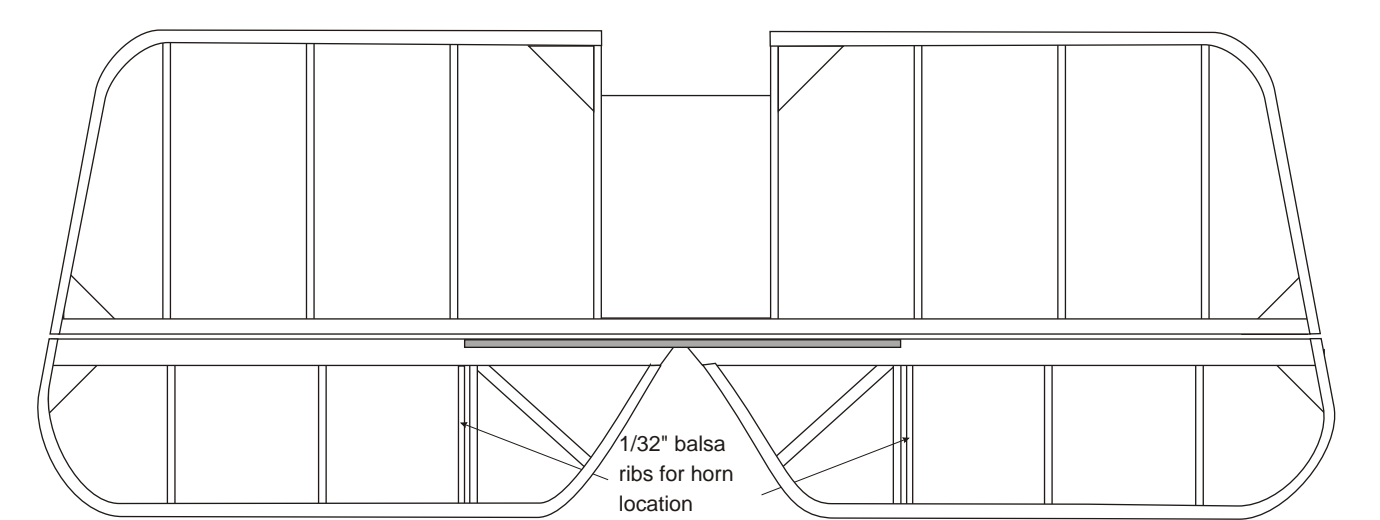

Tailplane from 1/16" strip as shown, outer curve 3x 1/64" x 1/16" ply laminated, 1.5mm CF rod joiner..